

VOLVO PENTA MARINE GENSET

D16 MG

415–525 kVA (332–420 kW_e) at 1500rpm 50Hz/400V, 488–596 kVA (390–477 kW_e) at 1800rpm 60Hz/440V

Volvo Penta Genset system

The Volvo Penta Genset systems are the complete solution for a ship's onboard power requirements. You will not only get reliable marine diesels, well-matched generators and a monitoring system, but also a wide range of products and services to optimize your investment.

Each Volvo Penta Genset is built in the Volvo factory fully adapted to the customer's requirements and comes complete and tested, ready for installation onboard.

The basis for the Volvo Penta Gensets is the smooth running and reliable marine diesel engines. Compact in design, they occupy less space in the engine room, and their good accessibility makes service and maintenance easy. Auto-start and synchronizing is rapid and reliable, meeting all standards with a comfortable margin.

All the Volvo Penta Gensets are type approved by the major classification societies, and can be delivered under complete certification.

Engine

The Volvo Penta engines are well balanced and have excellent emission performance. With growing care for the environment all over the world, emission regulations are becoming increasingly stricter. The D16 MG is certified for IMO NO_x limits and the comprehensive emission requirements according to EPA Tier 2, EU IWW and CCNR Stage 2.

Volvo's basic engine design in combination with a highly efficient speed control system gives superior load taking capability.

Generator

All the standard Gensets are equipped with a generator built by Newage Stamford. Stamford is the market leader in this power range and provides for worldwide service coverage. These generators are of a long proven design, based on years of experience of power generation for land-based and marine applications.



Warranty and service

For all Volvo Penta marine Gensets we can offer the additional benefit and security of the Cost Control Program, a unique system of operator support and financial control – from installation to after-sales service. This optional three-year warranty provides the owner peace of mind.

Qualified Volvo Penta dealers stand by for service and support in more than 100 countries all over the world. A complete set of documentation will be delivered with the set according to Volvo's high quality publication standard.

Technical Data Engine

Engine designation	D16 MG	
No. of cylinders and configuration	in-line 6	
Method of operation	4-stroke, direct-injected, turbocharged diesel engine with aftercooler	
Bore, mm	144	
Stroke, mm	165	
Displacement, l	16.1	
Compression ratio	17.5:1	
	1500 rpm	1800 rpm
Crankshaft Power HE Cooling, kW	450	500
Crankshaft Power RC Cooling, kW	433	470
Crankshaft Power KC Cooling, kW	450	500
Specific fuel consumption HE/KC, g/kWh	208 (50%)	212 (50%)
	203 (75%)	209 (75%)
	206 (100%)	213 (100%)
Recommended fuel to conform to	ASTM-D975 1-D & 2-D, EN 590 or JIS KK 2204	

10% overload available acc. to class requirements. Fuel temperature 40°C (104°F). Technical data according to ISO 3046 Fuel Stop Power with a tolerance ±4%. Fuel with a lower calorific value of 42700 kJ/kg and density of 840 g/liter at 15°C (60°F). Merchant fuel may differ from this specification which will influence engine power output and fuel consumption. The engine is certified according to IMO NO_x, EPA Tier 2, EU IWW and CCNR Stage 2.

D16 MG

Technical description

Complete Genset

- High system efficiency as a result of system optimization of the complete Genset
- All used components of highest quality from well reputed suppliers
- Reinforced set dimensioned for high output and low sound level
- Mono-block engine/generator rigidly mounted on a common bed frame
- Engine directly coupled to generator via a flexplate
- Flexible mountings including welding plates mounted under the frame

Engine and block

- Cylinder block and cylinder head made of cast iron
- One piece cylinder head
- Replaceable wet cylinder liners and valve seats/guides
- Drop forged crankshaft with induction hardened bearing surfaces and fillets with seven main bearings
- Four valve per cylinder layout with overhead camshaft
- Each cylinder features cross-flow inlet and exhaust ducts
- Gallery oil cooled forged aluminum pistons, three piston rings (keystone top ring)
- Senders for oil pressure (after filter), oil temp, oil pressure piston cooling, oil level, fuel pressure, freshwater pressure, exhaust temp, crankcase pressure, speed crank and cam, boost pressure/temp, seawater pressure (not KC or RC cool.), coolant level, coolant temp

Lubrication system

- Freshwater-cooled oil cooler integrated in cylinder block
- Twin full flow oil filter of spin-on type and single by-pass filter

Fuel system

- Electronic Unit Injectors
- Gear-driven fuel pump, driven by timing gear
- Electronically controlled injection timing
- 5-hole high pressure injector nozzles
- Twin engine-mounted spin-on fine fuel filters with change over valve

Turbocharger

- Dry twin entry turbocharger

Heat Exchanger cooled system (HE)

- For seawater- and central-cooled Gensets
- Engine-mounted tubular heat exchanger with expansion tank
- Belt-driven centrifugal freshwater pump
- Gear-driven rubber impeller raw water pump (optional)

Radiator cooled system (RC)

- For aircooled Gensets
- V-belt-driven radiator fan
- Belt-driven centrifugal cooling water pump
- Water-cooled CAC (Charge Air Cooler)

Keel cooled system (KC)

- 2-circuit cooling system
- Belt-driven centrifugal cooling water pump in HT circuit
- Engine mounted expansion tank in HT circuit
- Gear driven rubber impeller cooling water pump in CAC LT circuit

Generator

- 4-pole, brushless, AC marine generator
- Temperature rise class F
- Tropical insulation class H
- Stator winding as standard with short 2/3 pitch winding, ideal for non-linear load (thyristor load)
- Automatic Voltage Regulator (AVR) for accurate voltage regulation
- Permanent magnet mounted on generator for independent power supply to AVR
- Single bearing generator as standard
- Voltage available range up to 690V
- IP23 enclosure as standard
- Anti condensation heating

Control System

- MCC a new flexible and expandable control and monitoring system for classified installations. Incl. separate safety shutdown system
- Meets new classification requirements of separate shutdown and monitoring system
- Easy to interface with leading suppliers of ship control systems
- Possibility to connect relays for remote control functions (potential free contacts)
- Classifiable by all major classification societies

Optional equipment

Engine

- Twin fuel pre-filters/water separator with change over valve
- Flexible exhaust compensator
- Cooling water connection bellows
- Electrical, air or hydraulic starting systems in various combinations.
- Raw water pressure indication (only in combination with raw water pump)
- Exhaust temperature indication
- Engine heater 2000W

Generator

- Air inlet filters according to IP23
- Air inlet louvres/filters according to IP44
- Parallel equipment mounted in generator
- Thermistors (1 or 2 per phase) mounted in generator for temperature measurement of windings in generator
- PT100 elements (1 or 2 per phase) mounted in generator for temperature measurement of windings in generator
- Double bearing generator
- PT100 elements mounted in generator bearings for temperature measurement

Miscellaneous

- Dry exhaust silencer with or without spark arrester
- Batteries
- Battery main switch according to IP44
- Battery charger
- 80A alternator with integrated charging sensor
- Basic toolkit
- Spare parts according to classification recommendations

Contact your local Volvo Penta dealer for further information. Not all models, standard equipment and accessories are available in all countries. All specifications are subject to change without notice. The Genset illustrated may not be entirely identical to production standard Gensets.

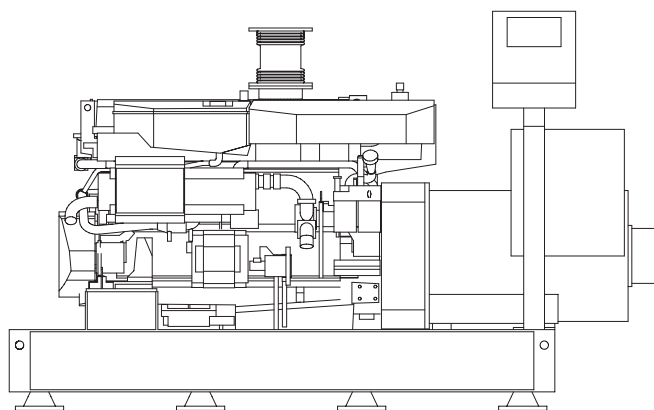
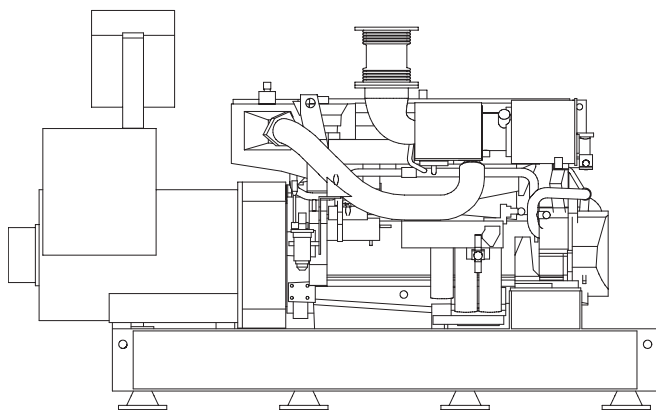

Technical Data HE Genset

Power output at 1500 rpm 50Hz/400V, kVA (kWe)

D16 MG / HCM534D-1	415 (332)
D16 MG / HCM534E-1	490 (392)
D16 MG / HCM534F-1	525 (420)

Power output at 1800 rpm 60Hz/440V, kVA (kWe)

D16 MG / HCM534D-1	488 (390)
D16 MG / HCM534E-1	588 (470)
D16 MG / HCM534F-1	596 (477)

10% overload available according to class requirements.

Fuel temperature 40°C (104°F). Technical data according to ISO 3046 Fuel Stop Power and ISO 8665. Fuel with a lower calorific value of 42700 kJ/kg and density of 840 g/liter at 15°C (60°F). Merchant fuel may differ from this specification which will influence engine power output and fuel consumption.

Dimensions L x W x H₁/H₂ (mm), not for installation

D16 MG / HCM534D-1	3131 x 1192 x 1842/1922
D16 MG / HCM534E-1	3131 x 1192 x 1842/1922
D16 MG / HCM534F-1	3206 x 1192 x 1842/1922

Weight, kg

D16 MG / HCM534D-1	3626
D16 MG / HCM534E-1	3776
D16 MG / HCM534F-1	3916

H₁ = Height including exhaust compensator

H₂ = Total genset height including control box

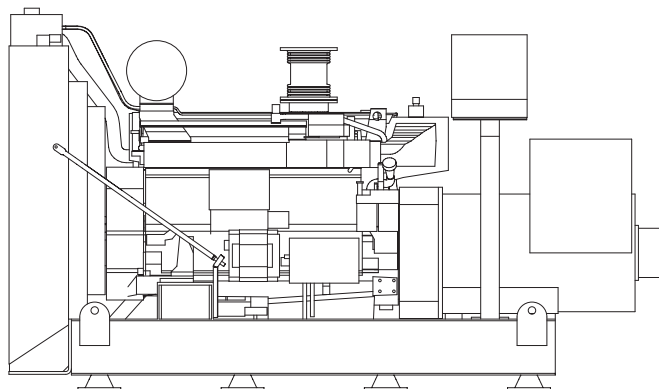
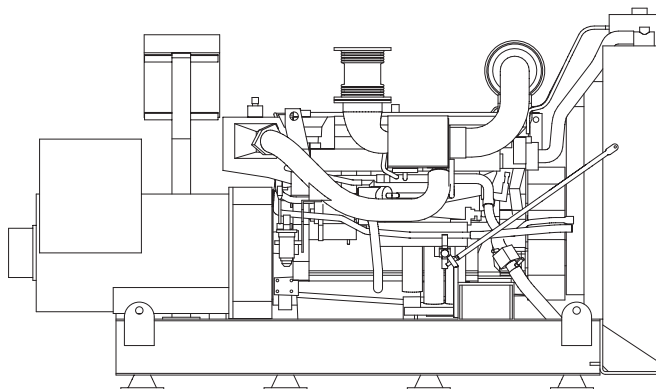

Technical Data rC Genset

Power output at 1500 rpm 50Hz/400V, kVA (kWe)

D16 MG / HCM534D-1	415 (332)
D16 MG / HCM534E-1	490 (392)
D16 MG / HCM534F-1	518 (414)

Power output at 1800 rpm 60Hz/440V, kVA (kWe)

D16 MG / HCM534D-1	488 (390)
D16 MG / HCM534E-1	560 (448)

10% overload available according to class requirements.

Fuel temperature 40°C (104°F). Technical data according to ISO 3046 Fuel Stop Power and ISO 8665. Fuel with a lower calorific value of 42700 kJ/kg and density of 840 g/liter at 15°C (60°F). Merchant fuel may differ from this specification which will influence engine power output and fuel consumption.

Dimensions L x W x H₁/H₂ (mm), not for installation

D16 MG / HCM534D-1	3430 x 1380 x 1843/2055
D16 MG / HCM534E-1	3430 x 1380 x 1843/2055
D16 MG / HCM534F-1	3505 x 1380 x 1843/2055

Weight, kg

D16 MG / HCM534D-1	3808
D16 MG / HCM534E-1	3958
D16 MG / HCM534F-1	4100

H₁ = Height including exhaust compensator

H₂ = Total genset height including expansion tank

D16 MG

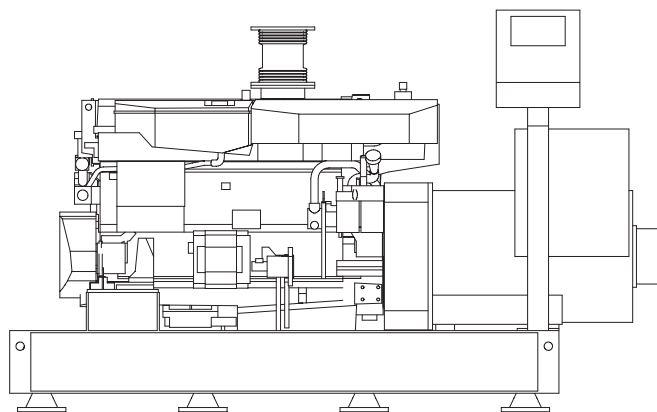
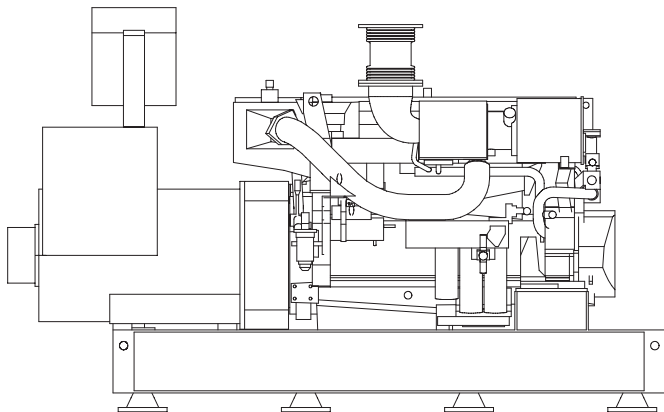

Technical Data KC Genset

Power output at 1500 rpm 50Hz/400V, kVA (kWe)

D16 MG / HCM534D-1	415 (332)
D16 MG / HCM534E-1	490 (392)
D16 MG / HCM534F-1	525 (420)

Power output at 1800 rpm 60Hz/440V, kVA (kWe)

D16 MG / HCM534D-1	488 (390)
D16 MG / HCM534E-1	588 (470)
D16 MG / HCM534F-1	596 (477)

10% overload available according to class requirements.

Fuel temperature 40°C (104°F). Technical data according to ISO 3046 Fuel Stop Power and ISO 8665. Fuel with a lower calorific value of 42700 kJ/kg and density of 840 g/liter at 15°C (60°F). Merchant fuel may differ from this specification which will influence engine power output and fuel consumption.

Dimensions L x W x H₁/H₂ (mm), not for installation

D16 MG / HCM534D-1	3131 x 1192 x 1842/1922
D16 MG / HCM534E-1	3131 x 1192 x 1842/1922
D16 MG / HCM534F-1	3206 x 1192 x 1842/1922

Weight, kg

D16 MG / HCM534D-1	3571
D16 MG / HCM534E-1	3721
D16 MG / HCM534F-1	3861

H₁ = Height including exhaust compensator

H₂ = Total genset height including control box

VOLVO PENTA

AB Volvo Penta
SE-405 08 Göteborg, Sweden
www.volvopenta.com